

INSTALLATION AND SAFETY INSTRUCTIONS

FOR YOUR SAFETY

WARNING: BE SURE THE ELECTRICITY TO THE WIRES YOU ARE WORKING ON IS SHUT OFF. EITHER THE FUSE REMOVED OR THE CIRCUIT BREAKER OFF .

GENERAL

You don't need special tools to install this fixture. Be sure to follow the steps in the order given. Under no circumstances should a fixture be hung on house electrical wires, nor should a swag type fixture be installed on a ceiling which contains a radiant type heating system. Read instructions carefully. **If you are unclear as to how to proceed, consult a qualified electrician.**

NOTE: Proper wiring is essential for the safe operation of this fixture.

ASSEMBLY

Carefully remove the fixture from the carton and check that all parts are included, as shown in Figure 1. Be careful not to misplace any of the screws or parts which are needed to install this fixture.

STEP 1:

Insert plastic bushing (M) onto face plate (H) (if applicable).

CAUTION:

- If a minican type lamp (non-halogen) is specified for this fixture:
1. Warning: risk of fire. Use 60watt lamp max. Use non-halogen minican type lamp only.
 2. Lamp (bulb) gets hot quickly ! Turn off electric power and allow the lamp to cool before replacing the lamp, or installing or removing the spring.
 3. Do not look directly at lighted bulb.
 4. Minican type lamps to be used with this fixture are pressurized lamps and generate intense heat. Lamp protective shields (or springs) must be used.

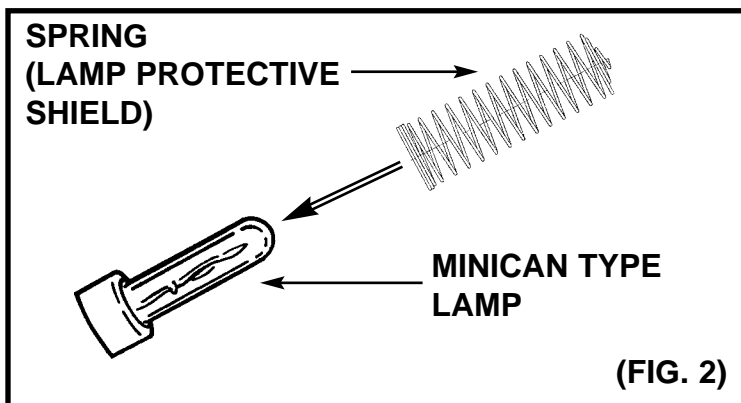
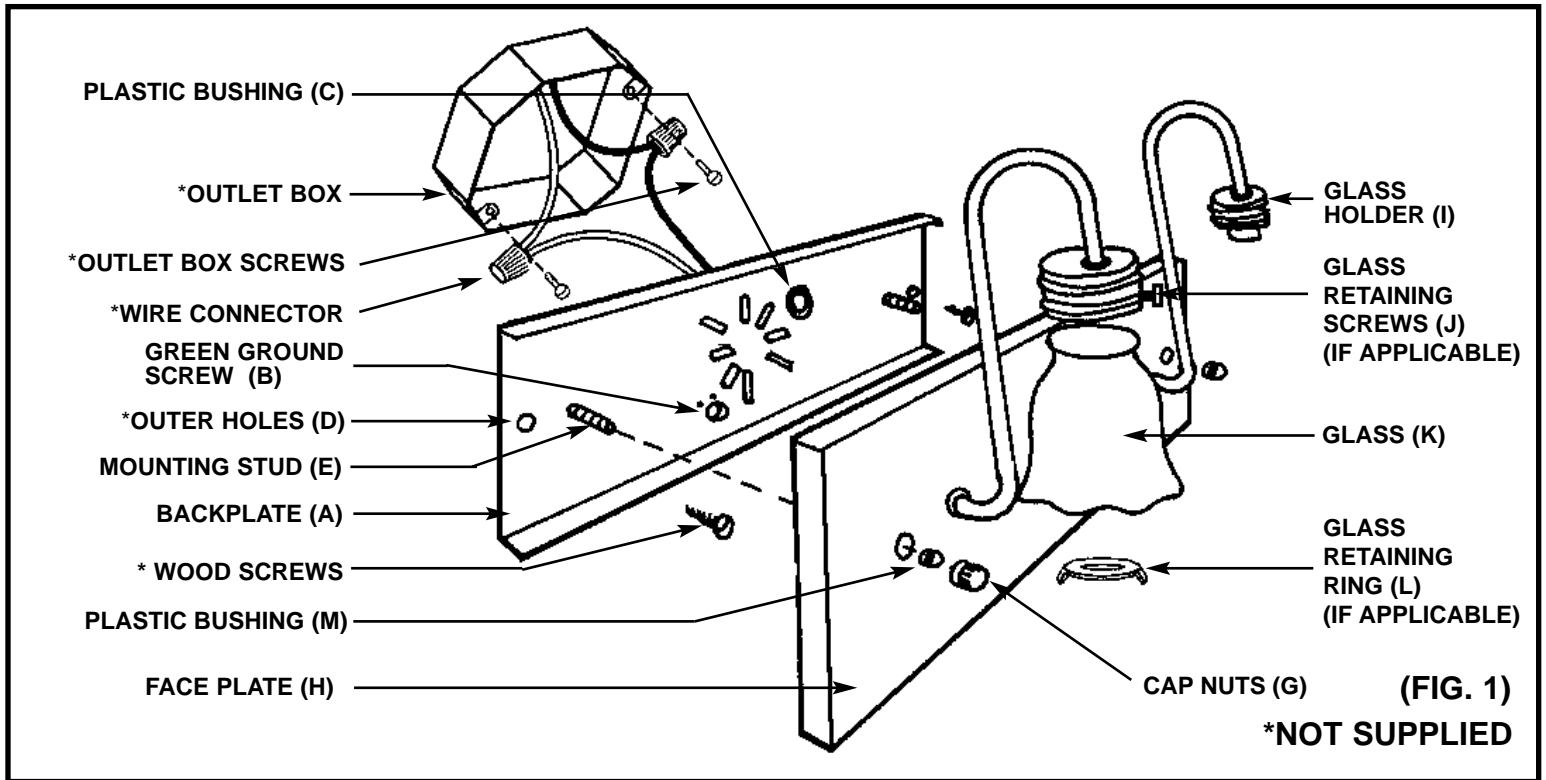



sea gull lighting®

Installation And Safety Instruction

HC-165 **100101**

Fill In Item Number On Carton And
File This Sheet For Fixture Reference. ITEM# _____

INSTALLATION

HC-165

STEP 1:

Punch out appropriate holes in backplate [A], if applicable, to correspond with holes in outlet box.

STEP 2:

Push socket wires thru plastic bushing (C).

STEP 3:

A. Take note of the color of the wire(s) on your fixture. Identify which group your fixture wire(s) falls into and connect the wires according to the directions below:

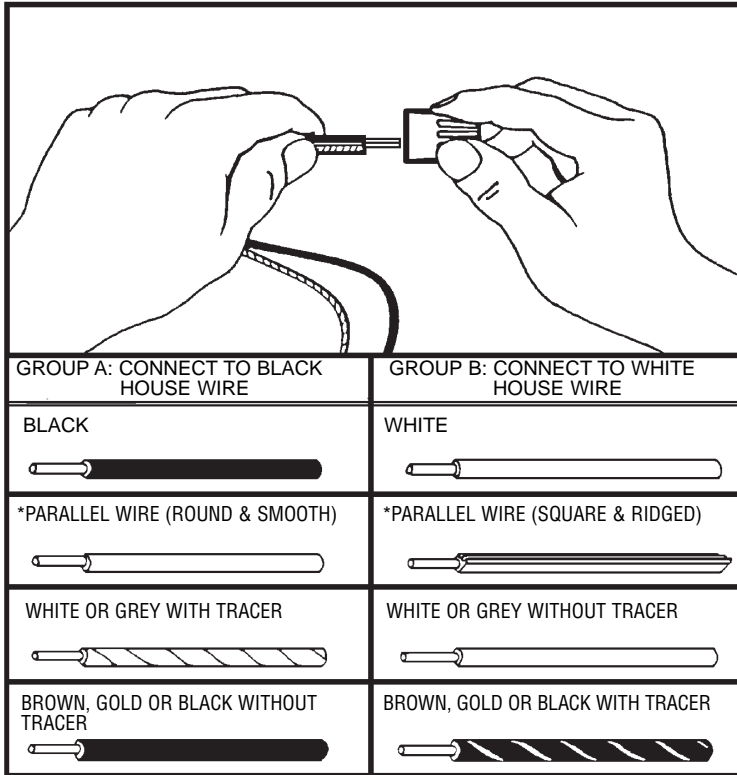

*NOTE: When parallel wire is used, the tracer wire is square shaped or ridged, and the less tracer wire is round in shape or smooth. (Seen best when viewed from wire end.) To separate wires, grasp the ends of each wire and pull apart.

B. Take your fixture wire(s) from group A and place evenly against the black wire from the outlet box. **Do Not** twist wires together before using wire connectors.

C. Fit a wire connector (not supplied) over the wires and screw the connector clockwise until you feel a firmness.

D. Try gently to pull the connector off the wires. If you can pull the connector off, carefully re-do steps B and C, as above, and check again for a firm connection.

E. Connect the fixture wire from group B to the white wire from the outlet box in the same manner.

STEP 4:

GROUNDING INSTRUCTIONS: The green grounding screw (B) is to be inserted into the hole with two raised dimples provided on the back plate (A). Wrap the ground wire from the fixture (if supplied) and the ground wire from the outlet box (bare metal or green insulated wire) around the green grounding screw (B) on the back plate (A).

NOTE: Underwriters Laboratories does not require all fixtures to have ground wires. These fixtures still meet all U.L. specifications.

NEVER CONNECT GROUND WIRE TO BLACK OR WHITE POWER SUPPLY WIRES.

FINAL ASSEMBLY

Make sure no bare wires can be seen outside wire connectors.

STEP 1:

Tuck wires into outlet box. Attach backplate (A) to outlet box by placing outlet box screws (not supplied) through punched out holes in backplate (A).

Wood screws placed in outer holes (D) will provide additional support.

STEP 2:

If backplate (A) is supplied with mounting studs (E) position faceplate (H) over studs (E) and secure in place with cap nuts (G).

STEP 3:

Attach glass (K) to glassholder (I), either with glass retaining screws (J), if applicable, or with glass retaining ring (L).

STEP 4:

Install lamps.

STEP 5: (If applicable.)

If a minican type lamp (non-halogen) is specified for this fixture, then you must install the lamp protective shield (supplied). See Fig. 2. Slide spring (lamp protective shield) over the lamp, onto the ceramic base of the lamp. Secure spring into place by turning spring clockwise over the ceramic base.

CLEANING

To clean, wipe fixture with a soft cloth. Clean glass with a mild soap. Do not use abrasive materials such as scouring pads or powders, steel wool or abrasive paper.

ORDERING PARTS

Keep this sheet for future reference, and in case you need to order replacement parts. All parts for this fixture can be ordered from place of purchase. Be sure to use exact wording from illustration when ordering parts.