

I20 Volt to I2 Volt 75W Remote Magnetic Transformer**94458 1.0****GENERATION LIGHTING****GENERAL PRODUCT INFORMATION:**

This transformer is safety listed for use with low voltage lighting systems offered by Ambiance Lighting.

This product is safety listed for indoor dry locations and approved for use at any height above the finished floor.

A typical installation is shown. Specific installation must be in accordance with the local electrical codes.

This product may be dimmed only with a low voltage magnetic dimmer. Using a dimmer not designed for low voltage magnetic applications may work initially, but could eventually cause transformer failure and will void the warranty. The dimmer must be derated as indicated by the dimmer manufacturer.

During installation, make sure all power connections are tight.

Read all instructions thoroughly. Read "Important Safety Information" on next column before proceeding with the installation.

Important Safety Information

Do not conceal or extend bus bar conductors through a building wall.

To reduce the risk of fire and burns, do not install this lighting system where the uninsulated open bus bar conductors can be shorted or contact any conductive materials.

To reduce the risk of the system overheating and possibly causing a fire, make sure all the connections are tight.

Do not install fixture assemblies closer than six inches to curtains or similarly combustible materials.

Turn the electrical power off before modifying the lighting system in any way.

The fixtures used with the system must be identified for use with the corresponding system.

To Reduce Risk of Fire, it is important to wire the remote transformer for the system as described in this installation instruction.

Do not exceed the maximum wattage of the remote transformer. The circuit of the transformer is only rated to this wattage.

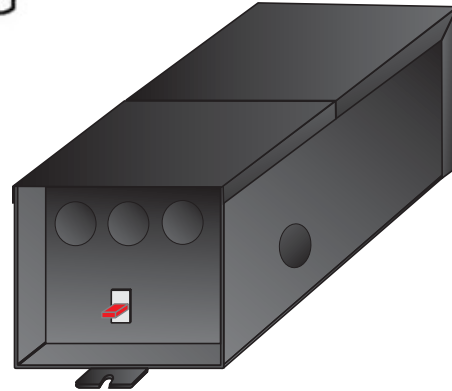
**CAUTION - RISK OF FIRE**

This product must be installed in accordance with the applicable installation code by a person familiar with the construction and operation of the product and the hazards involved.

Use minimum 90°C supply conductors.

Install the Remote Transformer

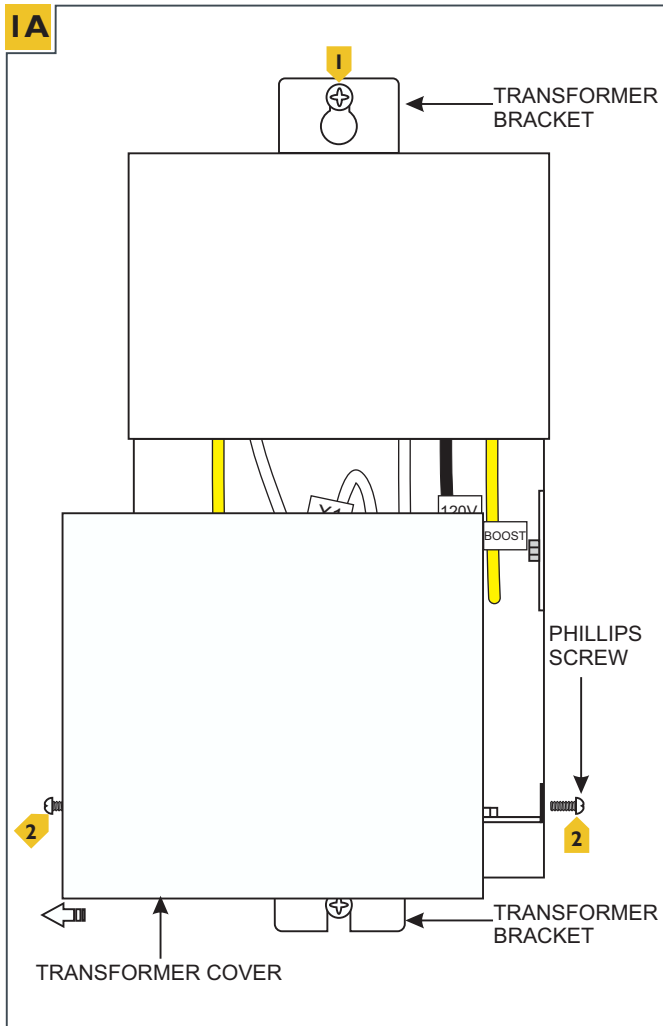

NOTE: In order to use small gage wires from the transformer to the electrical box, it is recommended to install the remote transformer near (if possible) the electrical box. See "Low Voltage Wire Size Table" below.

- 1** Mount the transformer to a solid surface using the keyhole slot on the mounting bracket (hardware not included).
- 2** Remove the transformer cover by loosening the two Phillips screws on the side of the transformer.

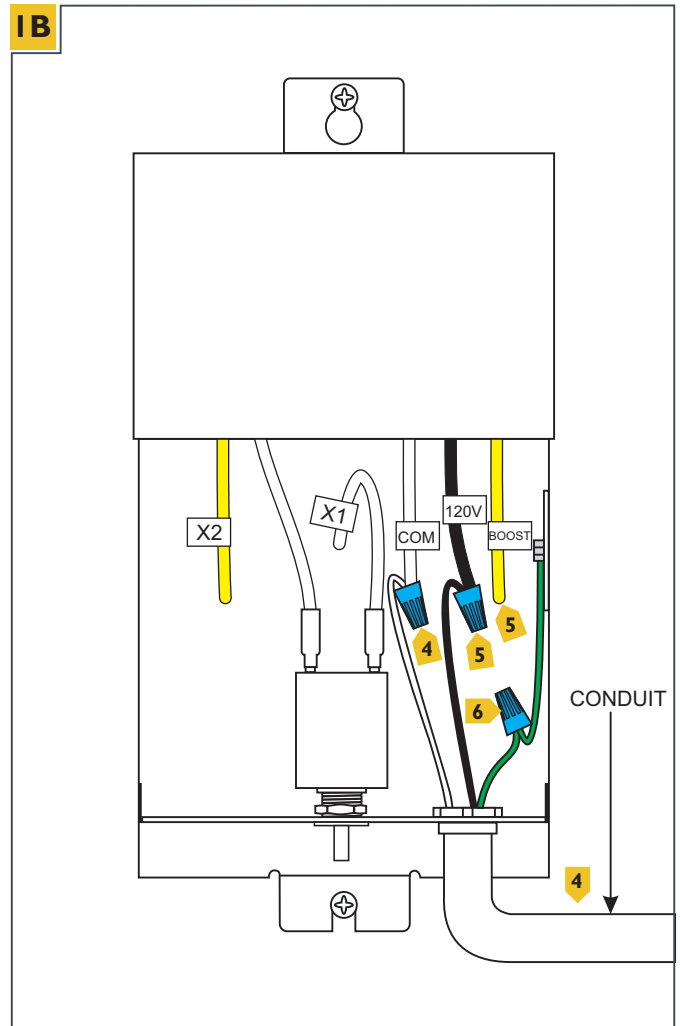

- 3** Install a conduit and power line wires from the panel to remote transformer.
- 4** Connect the white transformer wire marked "COM" to the neutral power line wire with a wire nut.
- 5** Connect the black transformer wire marked "120V" or the yellow transformer wire marked "boost" to the hot power line wire with a wire nut (cap off the unused boost or 120V tap with wire nut). Use boost tap only if input voltage is below 110V or if using a dimmer.
- 6** Ground the transformer in accordance with local electrical code.

LOW VOLTAGE WIRE SIZE TABLE						
TRANSFORMER WATTAGE	WIRE SIZE FOR 5 FT	WIRE SIZE FOR 6-15 FT	WIRE SIZE FOR 16-20 FT	WIRE SIZE FOR 21-40 FT	WIRE SIZE FOR 40-60 FT	WIRE SIZE FOR 61-90 FT
75 WATT	#14 GA	#12 GA	#10 GA	#8 GA	#6 GA	#4 GA

Check the System

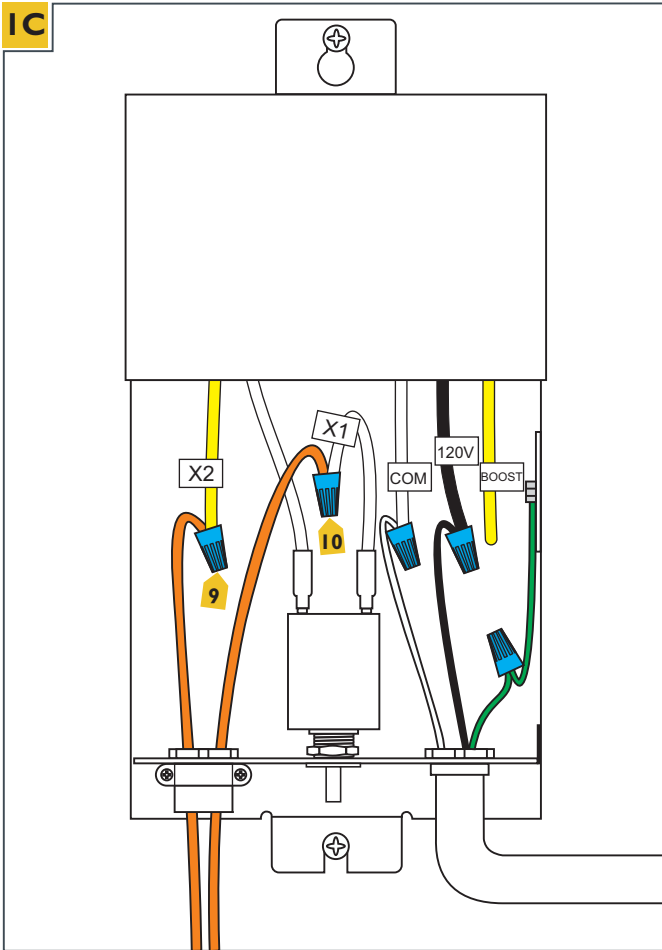

7 Install a conduit connector and bring the low-voltage connector wires from the fixture to the remote transformer.

8 For the best performance, use the "Low Voltage Wire

NOTE: Other wire sizes that comply with electrical code can be used, but may result in an increased voltage drop and reduced lamp intensity.

NOTE: The THHN wire sizes are for 3% or less drop in voltage based on 75 watt loads. Lengths are the distance from the transformer to the system power feed connector.

9 Connect one low voltage wire to the transformer wire marked "X1" with a wire nut.

10 Connect the second low voltage wire to the transformer wire marked "X2" with a wire nut.

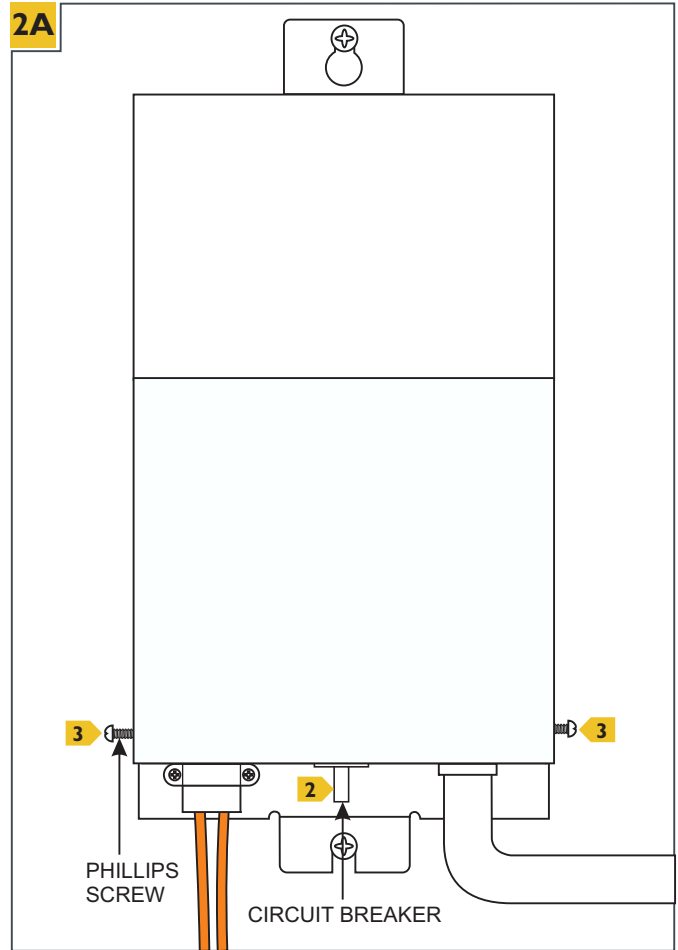

1 After installing the entire system, operate the system for five minutes.

2 The transformer circuit breaker will trip if there is a short in the system. After removing the cause of the short, the circuit breaker needs to be reset to power the system up.

3 Replace the transformer cover and tighten the two Phillips screws on the sides of the transformer.