

INSTALLATION AND SAFETY INSTRUCTIONS HC-669

U.S. PAT. # 5,465,199

INSTRUCTIONS FOR INSTALLATION OF THE AMBIANCE® TRANSFORMER

WARNING: Be sure the electricity to the wires you are working on is shut off; either the fuse removed or the circuit breaker off.

This plug in electronic transformer has (2) Class II outputs (each 60w max), for this transformer to operate the wattage load must be a minimum of 15w, but must not exceed 60w on each output.

FOR PROPER OPERATION OF AN ELECTRONIC TRANSFORMER, THE WATTAGE LOAD MUST FALL WITHIN THE SPECIFIED RANGE. IF THE LOAD DOES NOT FALL WITHIN THIS RANGE, THE TRANSFORMER MAY MALFUNCTION OR LAMPS MIGHT FLICKER.

TRANSFORMER INSTALLATION

Select the desired location to mount the transformer (not in contact with insulation & away from oven or any other source of intense heat). Using the two screws (provided), fasten the transformer and mounting tab to the mounting surface.

INSTALLATION OF 120V QUICK CONNECT PLUG

1. Cut off end of 120v cord cleanly and evenly. **CAUTION: Do not separate wires. Do not remove or damage insulation (Figure 2).**
2. Press cord, with ridged side to the right (tracer wire), down and into front of plug.
3. Press cord down onto metal prongs.
4. Slide plug cover over cord and plug until plug cover is centered over plug.

INSTALLING SWITCH ON 120V CORD

NOTE: Switch must be mounted a least 1 1/2" away from any metal parts.

NOTE: When parallel wire (SPT II) is used, the tracer wire is square shaped or ridged and the non-tracer wire is round in shape or smooth (seen best when viewed from wire end).

1. Split 120v cord as illustrated (FIGURE 3). Cut the non-tracer (or smooth) wire. Be sure to cut only the smooth non-tracer wire.
2. Remove the screw from the switch and take the switch apart.
3. Place the wires in part A (without the wheel) as shown. Tuck the cut wire down one end on each side of the barrier.
4. Press both halves of the switch back together. Note that the points pierce insulation to make contact with copper inside wire.
5. Place screw back into center hole and secure in place with nut.

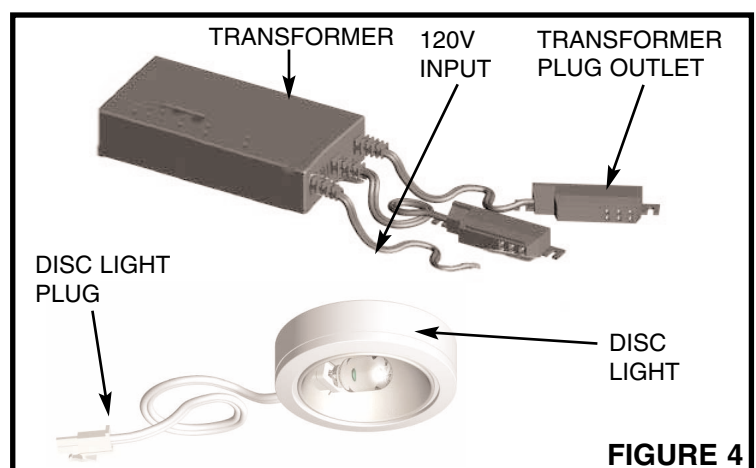
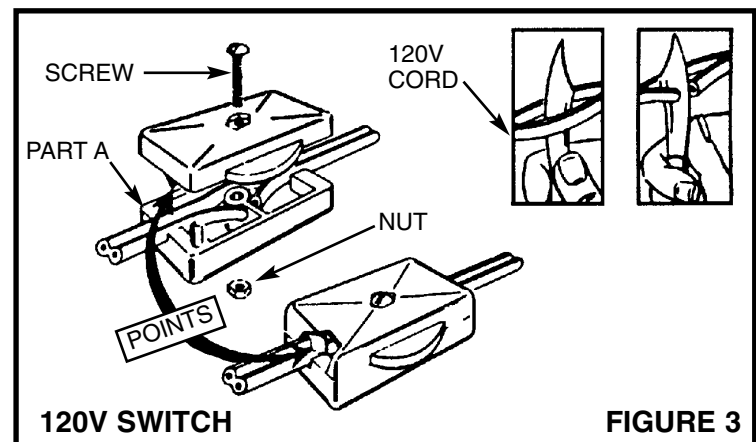
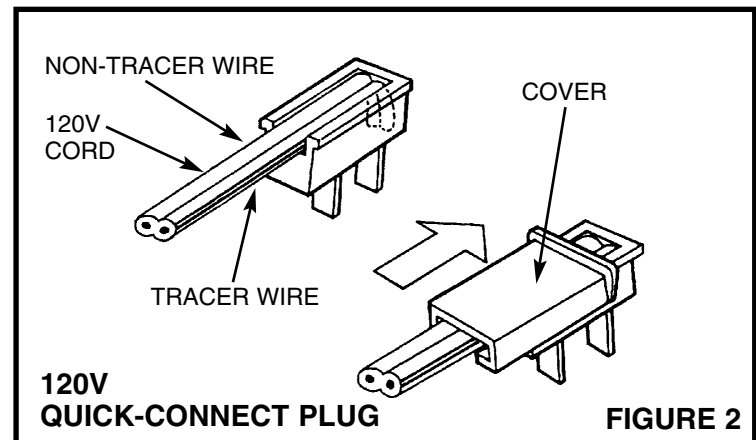
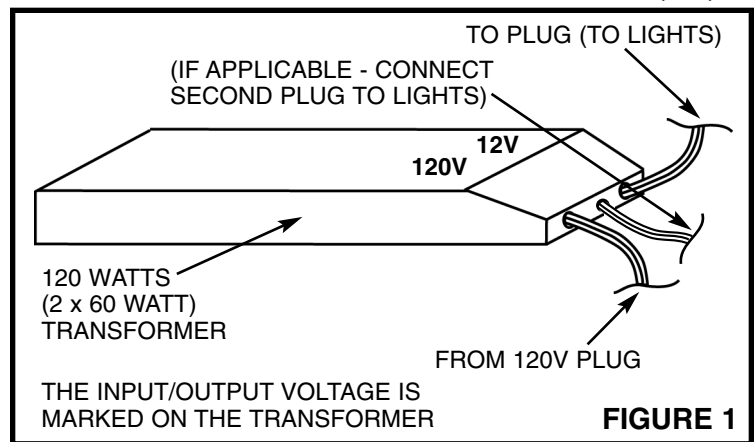

LOW VOLTAGE OUTPUT CONNECTIONS (12vac)

Insert plug from fixture into transformer plug outlet.

IMPORTANT SAFETY INSTRUCTIONS

This transformer has a polarized plug (one blade is wider than the other). As a safety feature, this plug will fit in a polarized outlet only one way. If the plug does not fit fully in the outlet, reverse the plug.

If it still does not fit, contact a qualified electrician. Never use with an extension cord unless plug can be fully inserted. Do not attempt to defeat this safety feature.

FINAL ASSEMBLY

To control transformer, install ON/OFF switch or good quality low voltage electronic dimmer on the 120V side of transformer.

DO NOT NAIL OR SCREW THROUGH CABLE TO ATTACH TO A SURFACE. Use 9430 sleeving to cover wire when going through holes in combustible materials, or notch the cabinet wall.

NOTE: As with all electronic transformers, there is a potential for Radio Frequency Interference (R.F.I.). To reduce R.F.I., rotate the electronic transformer in relation to the input line, or switch to a magnetic transformer.