

INSTALLATION AND SAFETY INSTRUCTIONS

FOR YOUR SAFETY

WARNING: BE SURE THE ELECTRICITY TO THE WIRES YOU ARE WORKING ON IS SHUT OFF. EITHER THE FUSE REMOVED OR THE CIRCUIT BREAKER OFF .

GENERAL

You don't need special tools to install this fixture. Be sure to follow the steps in the order given. Read instructions carefully. **If you are unclear as to how to proceed, consult a qualified electrician.**

ASSEMBLY

Carefully remove the fixture from the carton and check that all parts are included, as shown in Figure 1 & 2. Be careful not to misplace any of the screws or parts which are needed to install this fixture.

INSTALLATION INSTRUCTION FOR MODEL 1140 OR 1141

1. Mount fixture to ceiling structure extending adjustable hanger bars, and firmly mount to ceiling joist support members. Please note: When installing to wood joist, the convenient mounting spike may be used to hold the hanger bars temporarily in place. The installation must then be completed with proper fasteners (not provided).
2. To make electrical connections:

NEVER CONNECT GROUND WIRE TO BLACK OR WHITE POWER SUPPLY WIRES.

- a. Connect 1/2", flexible conduit (120V supply wires) to junction box with suitable connector.
 - b. Connect black supply wire to black wire in junction box with wire connector.
 - c. Connect white (neutral) supply wire to red or white wire in junction box with wire connector.
 - d. Complete ground connection with bare copper wire or green grounding wire.
 - e. Replace J-Box cover by setting plate base into holder and locking at top with spring clip.
3. Position the housing so that the rim is flush with the finished ceiling opening.

NOTE: IF THE SYSTEM IS TO BE OPERATED ON A DIMMING DEVICE ONE MUST BE SUPPLIED THAT IS DESIGNED FOR USE WITH LOW VOLTAGE LIGHTING THAT USES A MAGNETIC TRANSFORMER.

CAUTION! INSULATION MUST BE KEPT A MINIMUM OF 3" AWAY ON SIDES AND NO INSULATION ON TOP OF THIS FIXTURE.

IF SUPPLY WIRES ARE LOCATED WITHIN 3" OF BALLAST, USE WIRE RATED FOR AT LEAST 90°C.

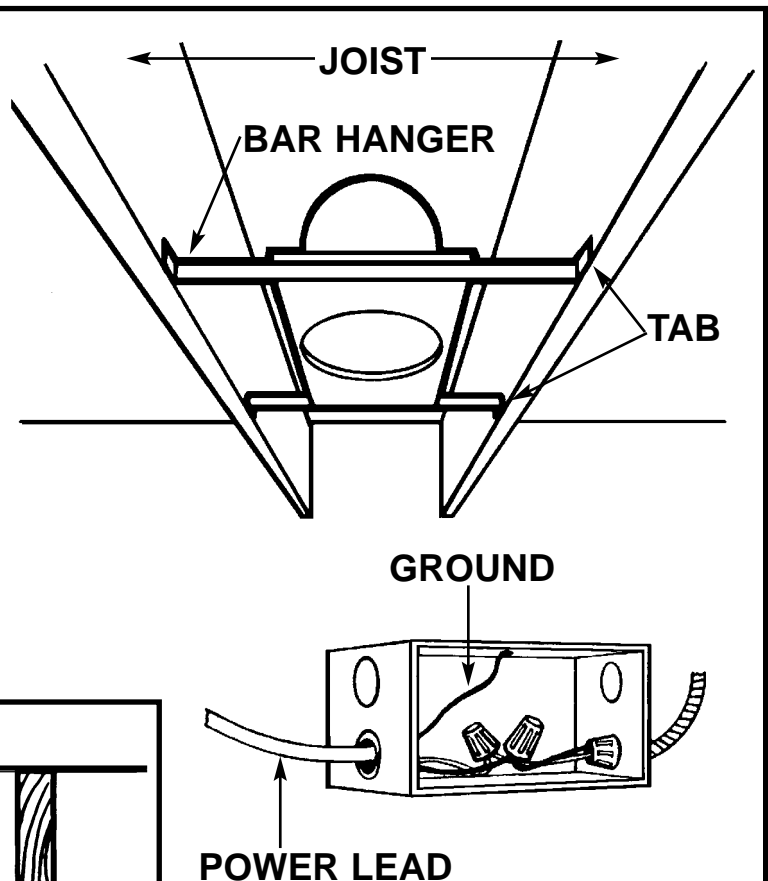

FIGURE 2

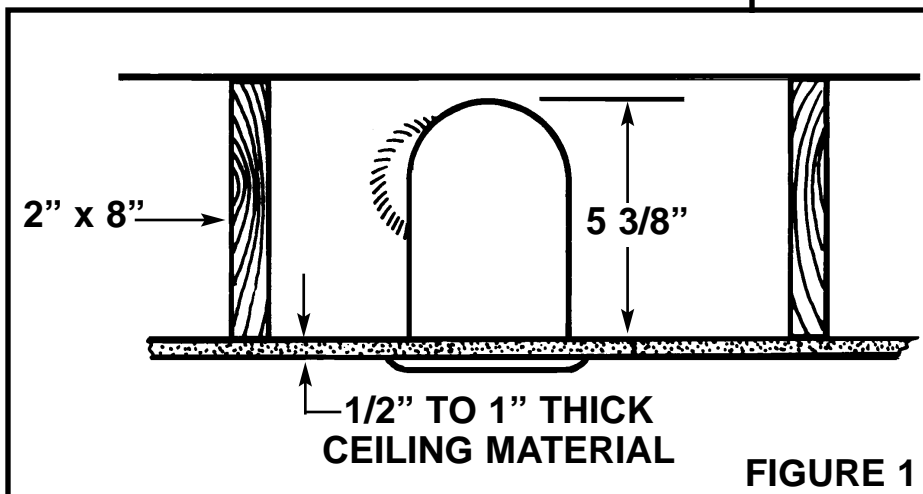

FIGURE 1

ITEM

Fill in item number located on carton and file this sheet for future reference

HC-287

050796

INSTALLATION INSTRUCTIONS FOR 1142 OR 1143 RECESSED COMPACT FLUORESCENT TRIMS

CAUTION: To avoid possible electrical shock, be sure that power supply is turned off before installing or servicing this fixture.

STEP 1:

TO INSTALL TRIM

NOTE: THE USE OF CLEAN PLASTIC FILM GLOVES IS RECOMMENDED WHEN HANDLING REFLECTORS. With the socket assembly (FIG. 3) to the trim (reflector) so that the socket tabs are in the inside of the trim and secure with supplied thumbscrew as shown. Tilt and insert the trim through the plaster frame opening as shown (FIG.4), allowing the screw on the yoke assembly to go into the hole in the top of the reflector. Thread supplied thumbnut onto screw of yoke assembly-HAND TIGHTEN ONLY!

STEP 2:

TO CLEAN TRIM

First, gently wipe with a soft, clean, dry, lint-free cloth to remove loose dust. Then use mild detergent solution on a soft, clean cloth to remove finger prints and stains. Rinse with clean, soft water and dry with lint-free cloth.

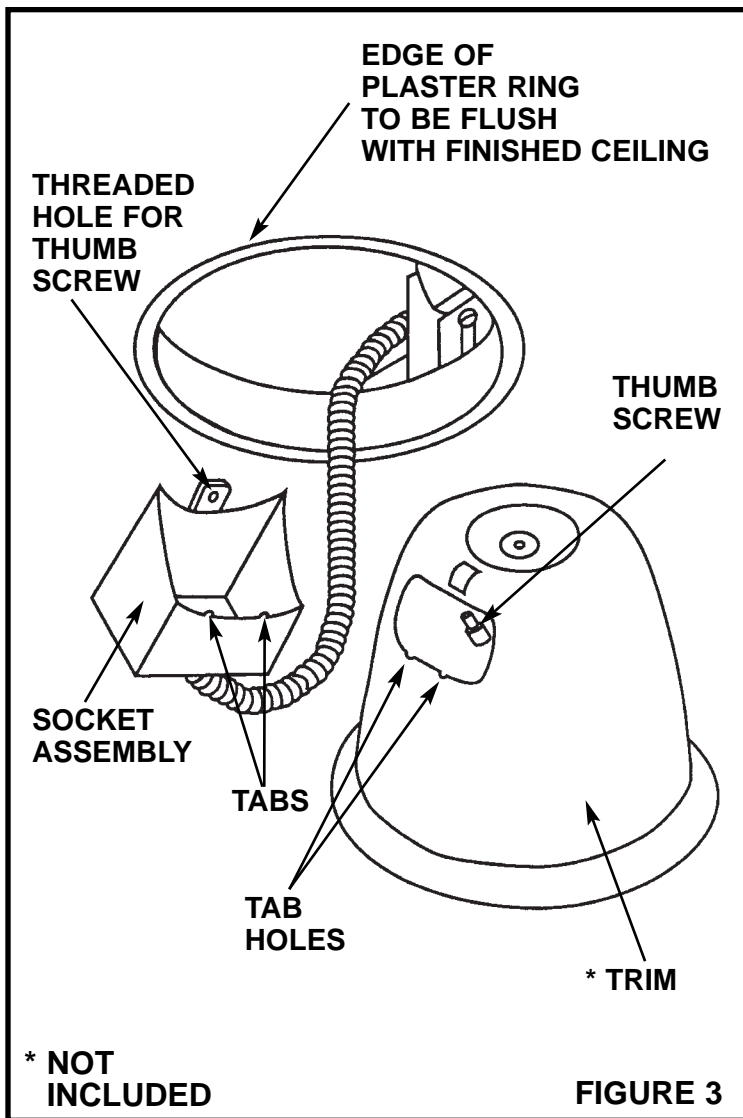

Make sure no bare wires can be seen outside wire connectors.

STEP 1:

TO INSERT LAMPS

Insert lamp tip through reflector slot, then press lamp base horizontally back into socket firmly until it snaps into place (FIG. 5).

ORDERING PARTS

Keep this sheet for future reference, and in case you need to order replacement parts. All parts for this fixture can be ordered from place of purchase. Be sure to use exact wording from illustration when ordering parts.

