

# INSTALLATION AND SAFETY INSTRUCTIONS

## FOR YOUR SAFETY

**WARNING:** Be sure the electricity to the system you are working on is turned off; either the fuse removed or the circuit breaker set off.

IF YOU ARE UNCLEAR AS TO HOW TO PROCEED, CONTACT A QUALIFIED ELECTRICIAN.

**CAUTION:** BE SURE TO CHECK YOUR TRANSFORMER TO DETERMINE THE VOLTAGE OF THE SYSTEM.  
**RISK OF FIRE:** USE ONLY 12V LAMPS WITH 12V SYSTEMS. USE OF 12V LAMPS WITH 24V SYSTEM MAY RESULT IN DAMAGE TO SYSTEM AND SURROUNDING AREA.  
**CAUTION:** MAXIMUM TRANSFORMER OUTPUT AT 12V IS 300W.

## IMPORTANT SAFETY INSTRUCTIONS

1. Minimum distance from the front of the lamp to combustible surfaces is 8".
2. Be sure to install the rail system where it can not be shorted out by conductive materials.
3. Make sure all connections are tight.

**WARNING:** Use of other manufacturers components will void warranty, E.T.L. listing and create a potential safety hazard.

**CAUTION - RISK OF FIRE. KEEP AWAY FROM COMBUSTIBLE MATERIALS. DIMMING HALOGEN LAMPS GREATLY REDUCES LAMP LIFE.**

## INSTALLATION OF STANDOFFS

1. Choose desired location for the support.
2. On drywall ceiling, drill  $\frac{3}{8}$ " diameter hole for supplied stand off toggle bolt. Insert toggle bolt screw into fitter. Secure fitter to ceiling by inserting wings on toggle bolt through ceiling, and tighten screw. On other surfaces use proper securing method (not supplied).
3. Thread stem onto fitter.
4. Raise rail into rail adapter.
5. Secure in place with adapter cap.

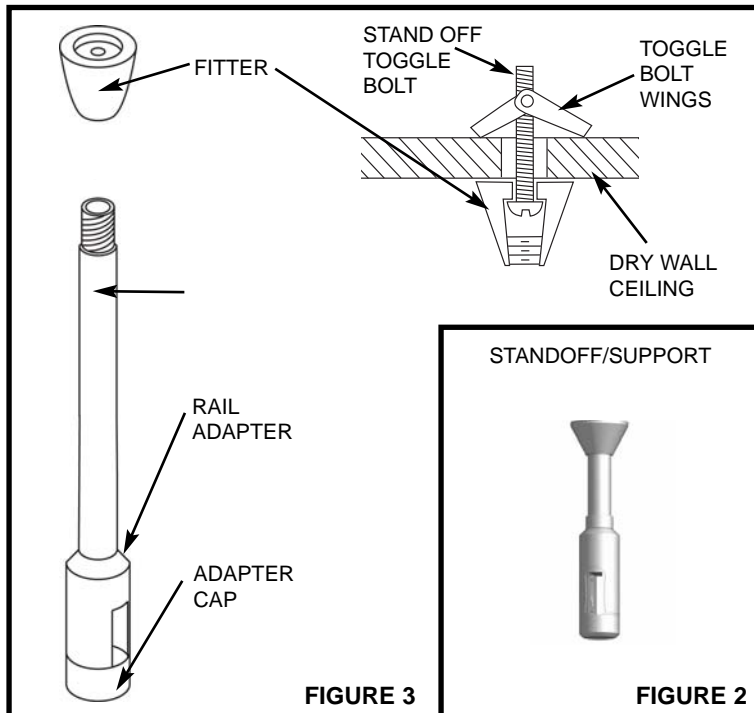

FIGURE 3

FIGURE 2

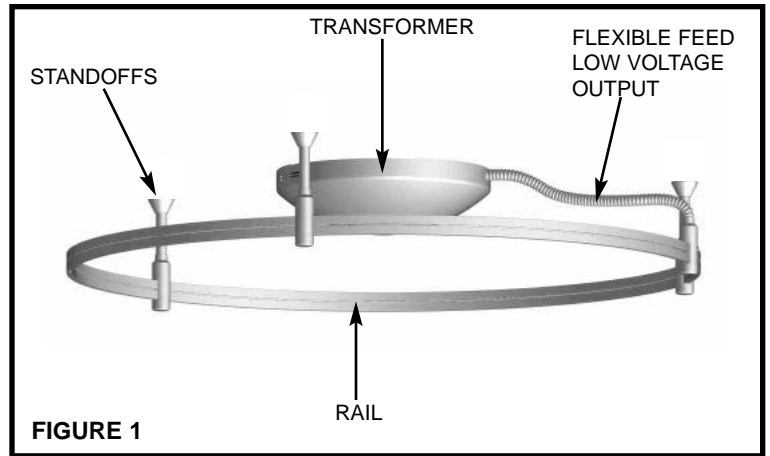

FIGURE 1

## GROUNDING AND MOUNTING BAR LOCK UP

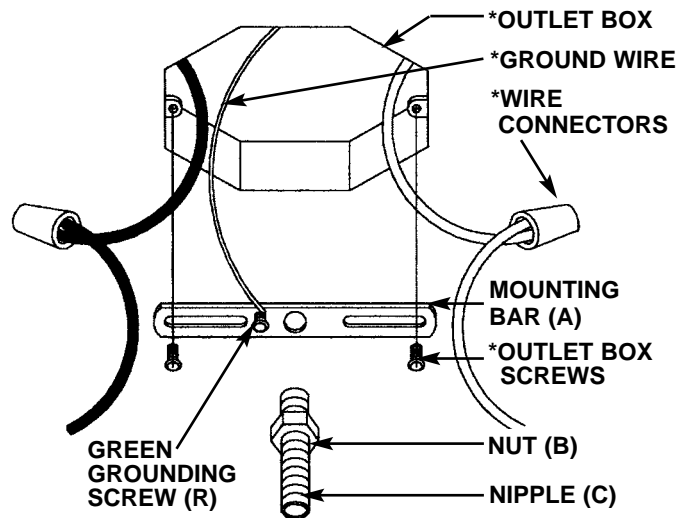

FIGURE 4

\*NOT INCLUDED



AMBIANCE<sup>®</sup>  
LIGHTING SYSTEMS

LV-037

121102

[www.SeaGullLighting.com](http://www.SeaGullLighting.com)

**INSTALLATION WITHOUT A JUNCTION BOX** LV-037

1. Open the "knock-out" hole in the canopy.
2. Install suitable cable connector (not supplied) to the canopy.
3. Bring 120v input cable (i.e. Romex, Bx, etc.) through canopy and secure with cable connector.
4. Install canopy to ceiling with appropriate mounting method (not supplied).
5. Proceed with wiring instructions.

**INSTALLATION OVER JUNCTION BOX**

1. Thread nipple (C) onto mounting bar until 3 threads are showing above mounting bar. Secure with nut (B).
2. Connect 120v black and white house wires (supply wires) to respective 120v transformer extension wires.
3. Feed 120v black and white extension transformer wires through nipple (C).
4. Secure mounting bar to outlet box with screws (not supplied).
5. Raise transformer canopy to ceiling so nipple (C) goes through the transformer center hole. Secure with washer and nut.

**WIRING**

NOTE: To dim, we recommend using a standard incandescent dimmer on the 120v side.

1. Using wire connectors (not supplied) connect the 120v black transformer wire to the 120v black transformer extension wire. Repeat with the 120v white transformer wire to the 120v white transformer extension wire.
2. Grounding: Connect the supplied ground wire to the green grounding screw on the mounting bar, or to the house ground wire.

**LOW VOLTAGE WIRING**

1. Snap circuit breaker into transformer cover.
2. Cut flexible feed to desired length and slide into the slot located on the cover.
3. (May be factory installed). Install low voltage flexible feed wires into terminal block. Tighten terminal block screws.

**FINAL INSTALLATION**

**CAUTION: Be certain to align the mounting adapter to the correct circuit. Each adapter has identifying ridges indicating the proper circuit location (See Figure 2)**

1. Insert cover ground wire located in the transformer canopy into ground wire plug located on the cover
2. Raise cover. Secure cover to canopy with cover screws.
3. Raise rail until it sits flush in rail adapter groove. Secure rail in place by threading adapter cap onto rail adapter.
4. Tighten set screws.
5. Follow instructions supplied with the optional fixtures.

**TROUBLESHOOTING**

If circuit breaker trips (button pops out) there may be either: (A) A short on the rail, or the fixtures on the rail; or (B) Too much wattage (more than the transformer's maximum output).

To solve "A" examine the rail to make sure each conductor is isolated. Remove all fixtures and install them back on the rail one at a time. (this will isolate the fixture with the short).

To solve "B" inspect the wattage markings on each lamp. Add up the wattage total and make sure it does not exceed the transformer's maximum wattage output. Possible solution reduce the lamp wattage or reduce the number of fixtures.

Once the problem is corrected reset the circuit breaker by pressing in the transformer's "popped out" button.

