

INSTALLATION AND SAFETY INSTRUCTIONS

FOR YOUR SAFETY

WARNING: Be sure the electricity to the system you are working on is turned off; either the fuse removed or the circuit breaker set at off.

IF YOU ARE UNCLEAR AS TO HOW TO PROCEED, CONTACT A QUALIFIED ELECTRICIAN.

CAUTION: BE SURE TO CHECK YOUR TRANSFORMER TO DETERMINE THE VOLTAGE OF THE SYSTEM.
RISK OF FIRE: USE ONLY 12V LAMPS WITH 12V SYSTEMS. USE OF 12V LAMPS WITH 24V SYSTEM MAY RESULT IN DAMAGE TO SYSTEM AND SURROUNDING AREA.
CAUTION: RISK OF FIRE: MAXIMUM WATTAGE FOR RAIL IS: 300W AT 12V; 500W AT 24V.
WATTAGE: 50W MAX: MRC-16.
THE OPTIONAL ACCESSORY RING (#94300) IS TO BE USED ON MR-16 LAMP (NOT MRC-16).
VOLTAGE: 12V OR 24V.

IMPORTANT SAFETY INSTRUCTIONS

1. Lamp gets hot quickly! Turn off and allow to cool to replace lamp.
2. **Do not** remain in light if skin feels warm.
3. **Do not** look directly at lighted lamp.
4. Lamps **should not** be touched with bare hands. (If the lamp is touched, wipe clean with a cloth and alcohol.)
5. Minimum distance from the front of the lamp to combustible surfaces is 8".
6. Be sure to install the rail system where it can not be shorted out by conductive materials.
7. Make sure all connections are tight.

WARNING: Use of other manufacturers components will void warranty, E.T.L. listing and create a potential safety hazard.

DIMMING HALOGEN LAMPS GREATLY REDUCES LAMP LIFE.

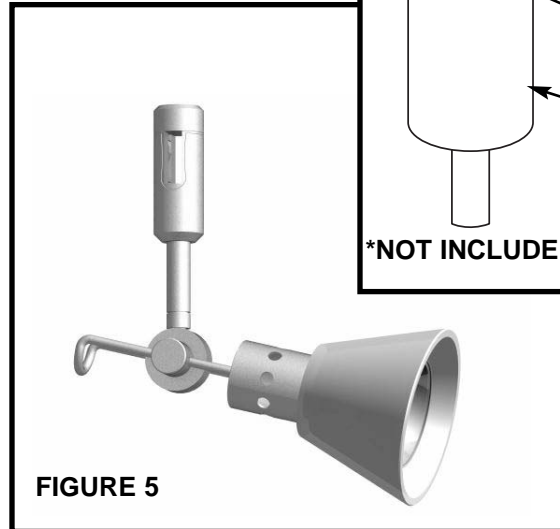
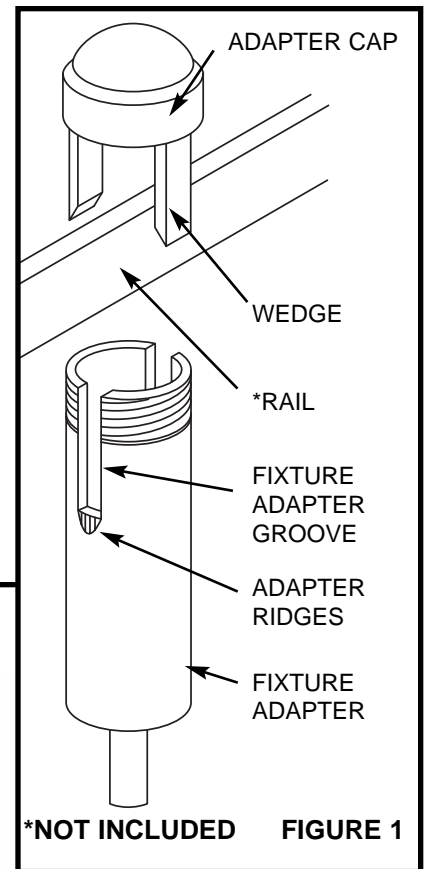

AMBIANCE®
LIGHTING SYSTEMS

LV-020

102502

www.SeaGullLighting.com

CAUTION: Be certain to align the mounting adapter to the correct circuit. Each adapter has identifying ridges indicating the proper circuit location (See Figure 2).

STEP 1:

Raise fixture adapter until rail sits flush in fixture adapter groove. Secure in place by threading adapter cap onto fixture adapter.

NOTE: The wedge located in the adapter cap is "keyed" (only fits one way). If it does not fit in the adapter, do not force it, rotate the wedge and reinsert it.

RAIL PROFILE CONTACTS FOR DUAL CIRCUIT RAILS

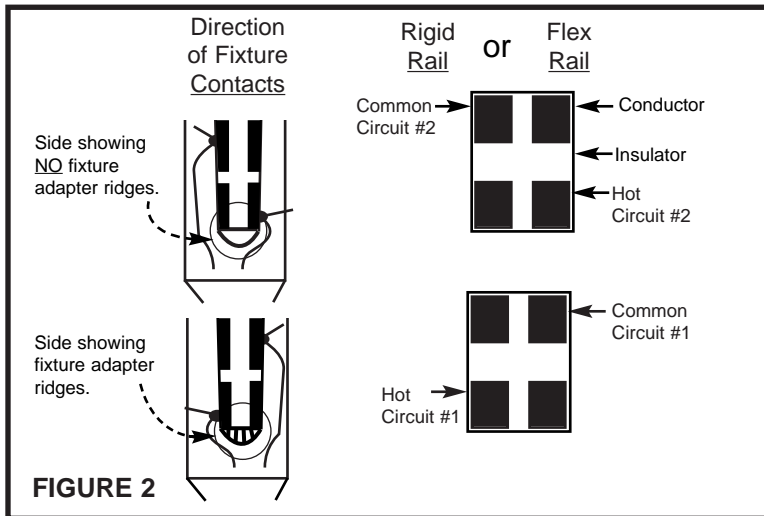

FIGURE 2

STEP 1:

On socket assembly (Fig.3 and Fig.4) install, shade, and finger tighten threaded ring until shade is secure.

STEP 2:

TO INSTALL LAMP: If using GY 6.35 Bi-Pin Halogen lamp (Fig.3), insert lamp into socket and install lamp protective cover over cover retaining springs. If using MR-16 type Halogen lamp (Fig.4), discard lamp protective cover and install lamp into socket making sure the lamp retaining spring snaps into the lamp's retaining notches located at the base of the lamp.

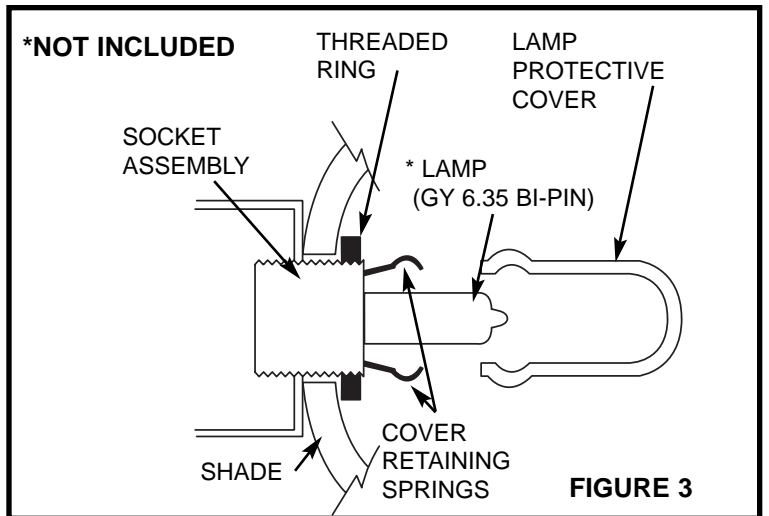

FIGURE 3

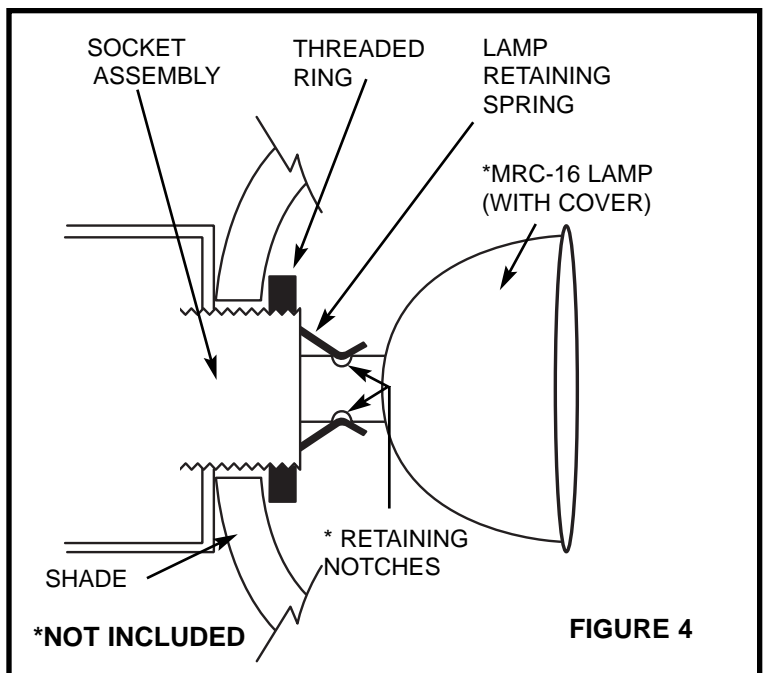

FIGURE 4