

# INSTALLATION AND SAFETY INSTRUCTIONS HC-185

## INSTRUCTIONS FOR INSTALLATION OF THE AMBIANCE STARTER SET 9498

**WARNING:** Be sure the electricity to the wires you are working on is shut off; either the fuse removed or the circuit breaker off.

**CAUTION:** TO PREVENT THE RISK OF FIRE, DO NOT INSTALL CLOSER THAN 2" TO CABINET WALL OR IN A COMPARTMENT SMALLER THAN 6" X 6" X 22". PLEASE KEEP AWAY FROM COMBUSTIBLE MATERIALS.

### TRANSFORMER INSTALLATION (FIGURE 1)

Select the desired location to mount transformer (not in contact with insulation and away from oven or any other source of intense heat, including other transformers).

NOTE: Transformer may come with double face tape, otherwise mount the transformer with screws (not supplied). If using the 3M double face tape provided on the transformer: use a cleaner with ammonia and make sure surface is dry and free from soap film, dirt, or grease. Remove paper on tape from transformer and apply firm pressure to secure it to a smooth surface. After wiring system, test system, then shut off for 24 hours to allow adhesive to actively create a firm bond with the surface. Or, use screws to mount transformer to surface. Transformer can be mounted in any direction. The wattage load must be a minimum of 20w for the transformer to operate, but must not exceed 60w.

NOTE: (If Applicable). The transformer has an 8 foot 120 volt cord with a plug molded at the end (FIGURE 2). If you require the length of the 120 volt cord to be shorter, **cut and discard the excess 120 volt cord with molded plug.** Follow the instructions below on how to install 120 volt quick-connect plug.

### INSTALLATION OF 120V QUICK-CONNECT PLUG

1. Cut off end of 120v cord cleanly and evenly. **CAUTION: Do not separate wires. Do not remove or damage insulation (Figure 3)**
2. Press cord, with ridged side to the right (tracer wire), down and into front of plug.
3. Press cord down onto metal prongs.
4. Slide plug cover over cord and plug until plug cover is centered over plug.

### INSTALLING SWITCH ON 120V CORD

NOTE: Switch must be mounted a least 1 1/2" away from any metal parts.

NOTE: When parallel wire (SPT I and SPT II) is used, the tracer wire is square shaped or ridged and the non-tracer wire is round in shape or smooth (seen best when viewed from wire end).

1. Split 120v cord as illustrated (FIGURE 4). Cut the non-tracer (or smooth) wire. Be sure to cut only the smooth non-tracer wire.
2. Remove the screw from the switch and take the switch apart.
3. Place the wires in part A (without the wheel) as shown. Tuck the cut wire down one end on each side of the barrier.
4. Press both halves of the switch back together. Note that the points pierce insulation to make contact with copper inside wire.
5. Place screw back into center hole and secure in place with nut.

### TRACK INSTALLATION

Attach track to surface with staples, nails or screws (not included). **Do not nail or screw through cable to attach to a surface.** If using 3M double face tape provided, attach tape to bottom of tracks. Use a cleaner with ammonia and make sure surface and track are dry and free from soap film, dirt, or grease.

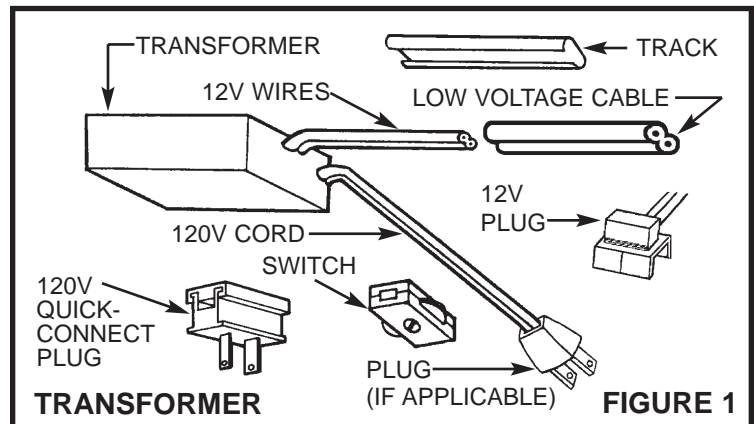

TRANSFORMER FIGURE 1

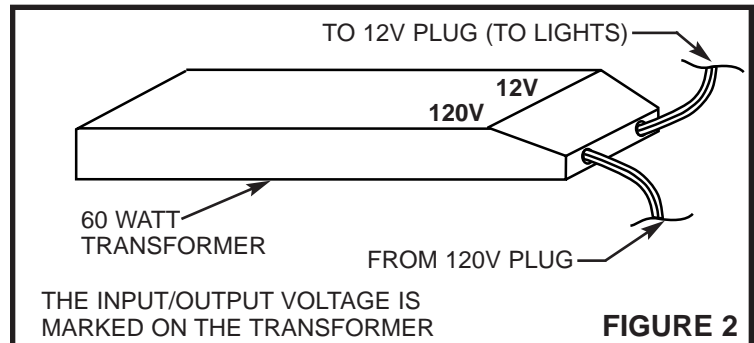

FIGURE 2

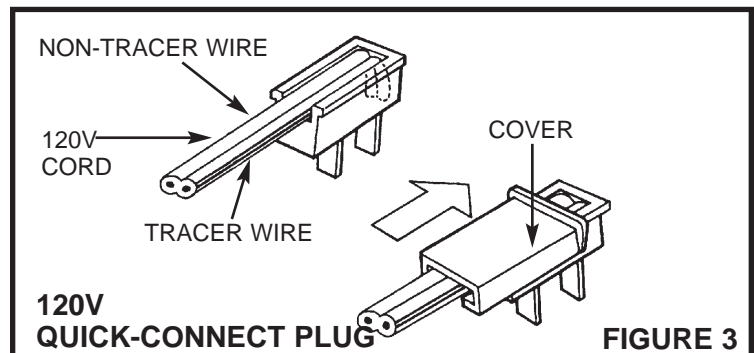
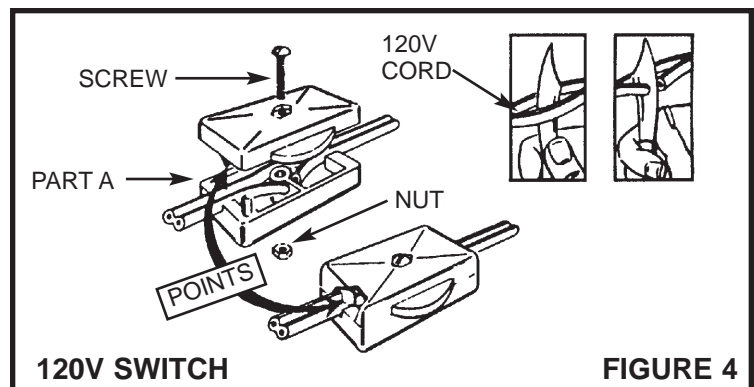

FIGURE 3



120V SWITCH FIGURE 4

Remove paper on tape from track and apply firm pressure to secure track to smooth surface. After wiring the low voltage system, test system, then shut off for 24 hours to allow adhesive to actively create a firm bond with the surface.

### CABLE INSTALLATION

Snap low voltage (12 volt) cable (heavy insulation cable marked "Ambiance by Sea Gull Lighting") onto track (already mounted to surface).

The 12 Volt wire that comes out from the transformer (the input/output voltage is marked on the transformer FIGURE 2). Connect the 12v wire from the transformer to the low voltage cable (heavy insulation wire) using the 12v plug.

**INSTALLATION OF 12V PLUG**

1. Cut 12v wire from transformer to desired length (FIGURE 5).
2. Split ends of wire (about 1/2") and insert each end of the wire as far as possible into the plug. Do not strip any insulation off the wire.
3. Insert contact into one end of 12V plug and press or use pliers until contact is flush with plug. Repeat with other contact (see FIGURE 5), on opposite side of 12v plug.
4. Twist wires sideways, insert into notch of 12v plug and twist back straight.
5. Snap 12v plug on low voltage cable which is already inside of the track (FIGURE 6).

**TO INSTALL SOCKETS**

**CAUTION:** Do not remove reflectors, heat from lamps will damage cable.

**NOTE:** Center of socket must be no closer than 2" to closed ends (wall surfaces, partitions).

1. Press socket straight down onto track and cable until socket snaps into place (minimum spacing between center of sockets is 4 inches).
2. Install bulbs (5w max.).

**WARNING: Use of other manufacturers components will void warranty, U.L. listing and create a potential safety hazard.**

**NOTE: As with all electronic transformers there's a potential for Radio Frequency Interference (R.F.I.). To reduce R.F.I., rotate the electronic transformer in relation to the input line, or switch to a magnetic transformer.**

**IMPORTANT SAFETY INSTRUCTIONS**

This starter kit has a polarized plug (one blade is wider than the other). As a safety feature, this plug will fit in a polarized outlet only one way. If the plug does not fit fully in the outlet, reverse the plug. If it still does not fit, contact a qualified electrician. Never use with an extension cord unless plug can be fully inserted. Do not attempt to defeat this safty feature.

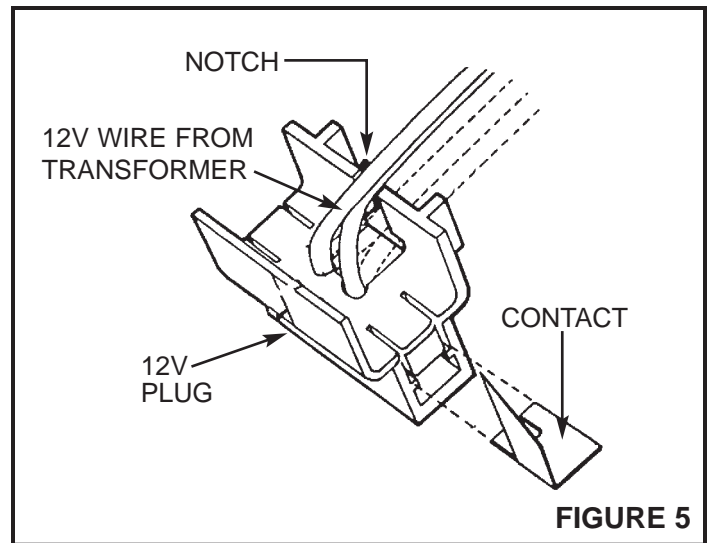

**FIGURE 5**

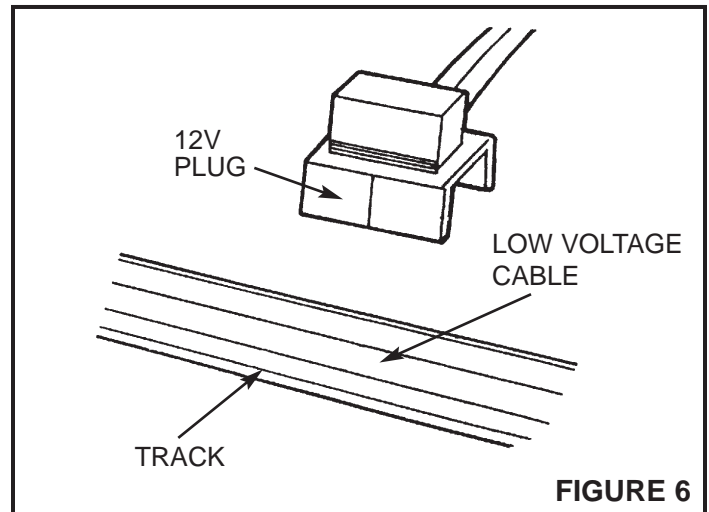

**FIGURE 6**

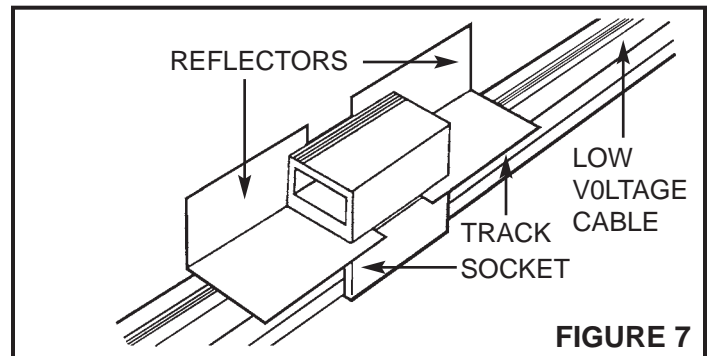

**FIGURE 7**