

INSTALLATION AND SAFETY INSTRUCTIONS

IMPORTANT SAFETY INSTRUCTIONS

- Be sure the electricity to the system you are working on is turned off; either the fuse removed or the circuit breaker set at off.
- Use of other manufacturers components will void warranty, listing and create a potential safety hazard.
- If you are unclear as to how to proceed, contact a qualified electrician.
- You don't need special tools to install this fixture.
- Be sure to follow the steps in the order given.
- Read instructions carefully.
- Save these instructions.

BEFORE YOU BEGIN

Carefully remove the fixture from the carton and check that all parts are included, as shown in Figures 1 & 2. Be careful not to misplace any of the screws or parts which are needed to install this fixture.

FOR STEM MOUNT

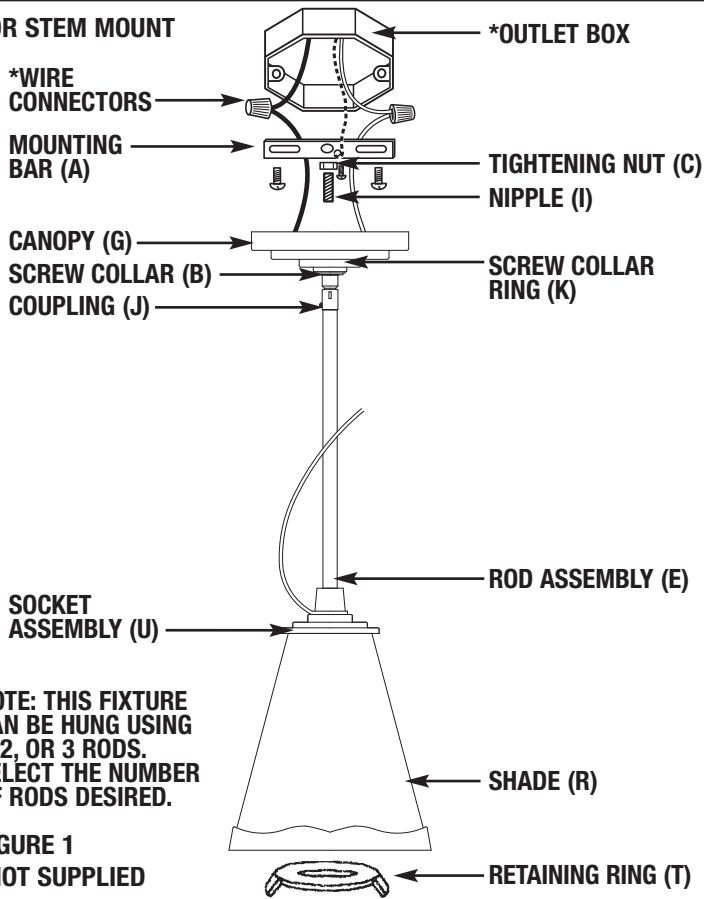

FOR STEM MOUNT (FIG. 1)

- STEP 1:** Secure mounting bar (A) to outlet box using outlet box screws (not supplied). Thread nut (C) onto nipple (I) so five threads are exposed. Thread nipple (I) to mounting bar (A) and secure by threading nut (C) to mounting bar (A). Thread screw collar (B) to nipple (I).
- STEP 2:** Assemble rod assembly (E) by threading desired amount of rods together.
- STEP 3:** Feed the fixture wire from the socket assembly (U), through: the rod assembly (E), coupling (J) (mounted on canopy (G)), and screw collar (B).
- STEP 4:** Slide screw collar ring (K) and canopy (G) (in that order) to top of socket assembly (U). Secure rod assembly (E) to coupling (J), and socket assembly (U). Be sure not to damage the fixture wire.

GROUNDING AND MOUNTING BAR LOCK UP

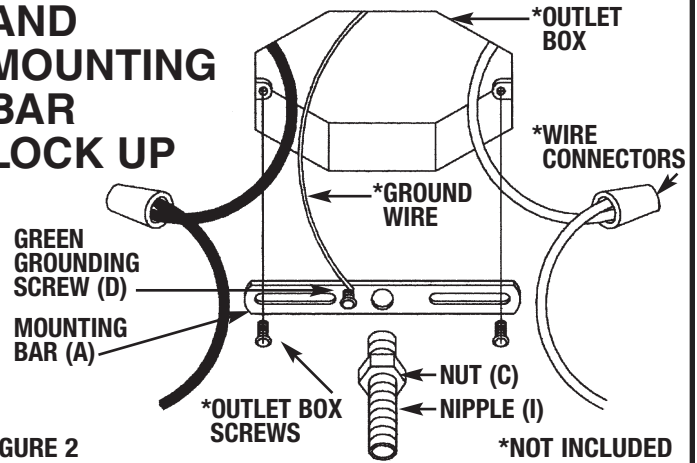

FOR CHAIN HUNG MOUNT (FIG. 2)

STEP 1:

Secure mounting bar (A) to outlet box using outlet box screws (not supplied).

STEP 2:

Thread nipple (I) into mounting bar (A) so 5 threads are above mounting bar. Secure by tightening nut (C) to mounting bar (A). Thread screw collar (B) and canopy loop (S) onto nipple (I).

STEP 3:

Install fixture loop (X) onto socket assembly (U).

FOR CHAIN HUNG

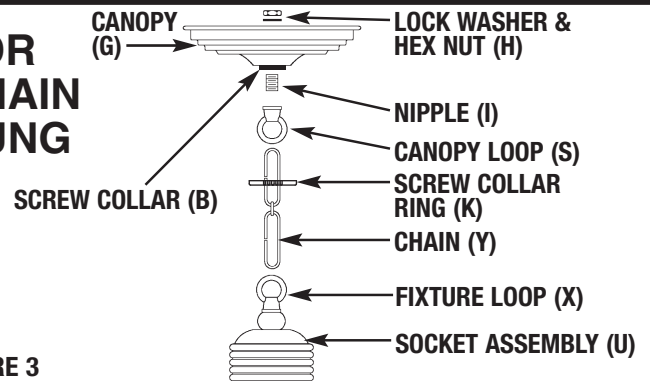

sea gull lighting®

Installation And Safety Instruction

HC-1137 111607

Line art shown may not exactly match the fixture enclosed. However, the installation instructions do apply to this fixture.

Fill In Item Number On Carton And File This Sheet For Fixture Reference. ITEM# _____

INSTALLATION

HC1137

IMPORTANT: DO NOT ATTACH FIXTURE DIRECTLY TO OUTLET BOX.

NOTE:

If desired, stem and chain can be used together. Thread fixture loop (X) into rod assembly (E) rather than threading fixture loop (X) directly into socket assembly (U).

FOR CHAIN HUNG ONLY (FIG. 3)

STEP 1:

Using 2 pair of pliers, open one link of chain (Y) and connect it to the fixture loop (X) at the top of the fixture. Slide screw collar ring (K) and canopy (G) on chain to fixture loop (X).

STEP 2:

Lace fixture wire up through entire chain (Y) and pass through canopy loop (S). We recommend lacing wire up through every other link of chain (Y). Open up other end of chain and connect to canopy loop (S). **BE SURE TO CLOSE ALL CHAIN LINKS COMPLETELY.**

WIRING

STEP 1:

A. Take note of the color of the wire(s) on your fixture. Identify which group your fixture wire(s) falls into and connect the wires according to the directions below:

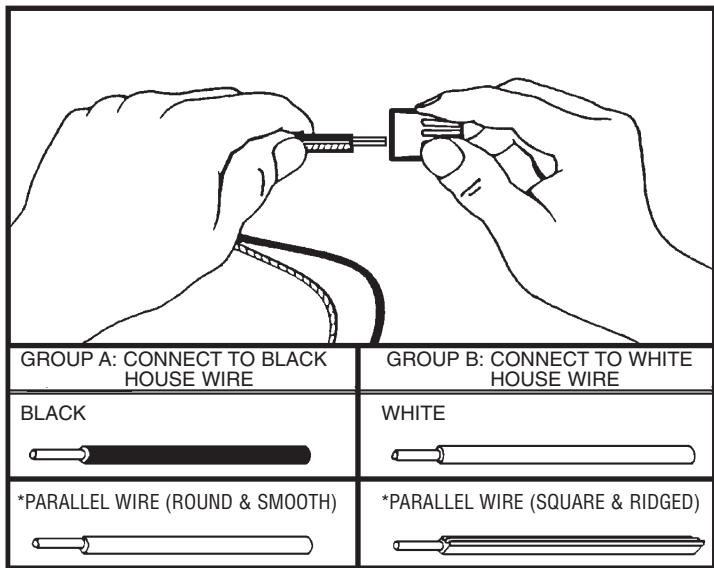

*NOTE: When parallel wire is used, the tracer wire is square shaped or ridged, and the less tracer wire is round in shape or smooth. (Seen best when viewed from wire end.) To separate wires, grasp the ends of each wire and pull apart.

- B.** Take your fixture wire(s) from group A and place evenly against the black wire from the outlet box. **DO NOT** twist wires together before using wire connectors.
- C.** Fit a wire connector (not supplied) over the wires and thread the connector clockwise until you feel a firm resistance.
- D.** Gently try to remove wires from connector. If you can remove wires, carefully re-do steps B and C, as above and check again for a firm connection.
- E.** Connect the fixture wire from group B to the white wire from the outlet box in the same manner.

STEP 2:

GROUNDING INSTRUCTIONS: The green grounding screw (D) is to be inserted into the hole with two raised dimples provided on the mounting bar (A). Wrap the ground wire from the fixture (if supplied) and the ground wire from the outlet box (bare metal or green insulated wire) around the green grounding screw (D) on the mounting bar (A). If uninsulated wire is on the mounting bar (A), connect the ground wire from the fixture (if supplied) and the outlet box to it using a small wire connector (not supplied).

NEVER CONNECT GROUND WIRE TO BLACK OR WHITE POWER SUPPLY WIRES.

FINAL ASSEMBLY

Make sure no bare wires can be seen outside wire connectors.

STEP 1:

After wires are connected, tuck them carefully inside outlet box and then raise the canopy (G) against the ceiling. Secure by threading screw collar ring (K) onto screw collar (B).

STEP 2:

Place shade (R) securely in socket assembly (U). Secure by threading retaining ring (T) onto socket.

STEP 3:

Install lamp.

CLEANING

To clean, wipe fixture body with a soft cloth. Clean glass with a mild soap. Do not use abrasive materials such as scouring pads or powders, steel wool or abrasive paper.

ORDERING PARTS

Keep this sheet for future reference, and in case you need to order replacement parts. Parts for this fixture can be ordered from place of purchase. Be sure to use exact wording from illustration when ordering parts.